



STANDARD SPECIFICATIONS

Performance

Platform Height	26-ft 7-in / 8.10-m
Horizontal Outreach	8-ft-9-in / 2.68-m
Up and Over Height	21-ft 4-in / 6.51-m
Swing	345 Degrees Non-continuous
Platform Capacity	500-lb / 227-kg
Platform Size	28 x 36-in / 70 x 90-cm
Weight*	6,900-lb / 3,130-kg
Ground Bearing Pressure	319 psi / 22.4 kg/cm ²
Ground Clearance	3.9-in / 10-cm
Drive Speed (Stowed)	3.4 mph / 5.5 km/h
Drive Speed (Elevated)	0.47 - .25 mph ¹ / 0.76 - .41 km/h
Gradeability	25%
Turning Radius (Inside)	1-ft-10-in / 55-cm
Turning Radius (Outside)	6-ft-6-in / 1.99-m

*Certain options or country standards increase weight

¹ .47 mph up to 23-ft 7.5-in platform height (with jib fully raised) / .25 mph above 23-ft 7.5-in platform height (with jib fully raised)

Power Source

Batteries	24V DC, 260 amp-hr AGM
Charger	27 amps

Brakes

Spring Applied Disc

Tires

16-in x 5-in Non-Marking

KEY SPECS

Platform Height
26-ft 7-in / 8.10-m

Up and Over Height
21-ft 4-in / 6.51-m

Horizontal Outreach
8-ft-9-in / 2.68-m

Platform Capacity
500-lb / 227-kg

KEY FEATURES

- Reach up and over obstacles in tight spaces with a vertical telescopic mast with a jib.
- Equipped for indoor jobs with standard non-marking tires and efficient electric power, and for outdoor work with 25% gradeability.
- Unmatched positioning capabilities with a 345 degree rotating mast.
- Optimum battery life and more duty cycles with AC direct electric drive.

STANDARD FEATURES

- 110V-AC Receptacle in the Platform
- 345 Degree Non-continuous Swing
- 5 Degree Tilt Alarm/Indicator Light
- All Motion Alarm
- Battery Condition Indicator
- ClearSky Smart Fleet™ Hardware (CS550)
- Emergency Lowering Pump
- Horn
- Hourmeter
- LED Motion/Amber Beacon (CS550)
- Lifting Eyes
- Load Sensing System
- Proportional Controls
- Platform, Saloon Gate
- SkyGuard SkyLine™
- Tie-down Lugs
- Warning Beacon

ACCESSORIES & OPTIONS

- 5/16-in Airline
- 70W Platform Work Light
- Console Cover
- Platform, Drop Bar

DIMENSIONS

All dimensions are approximate

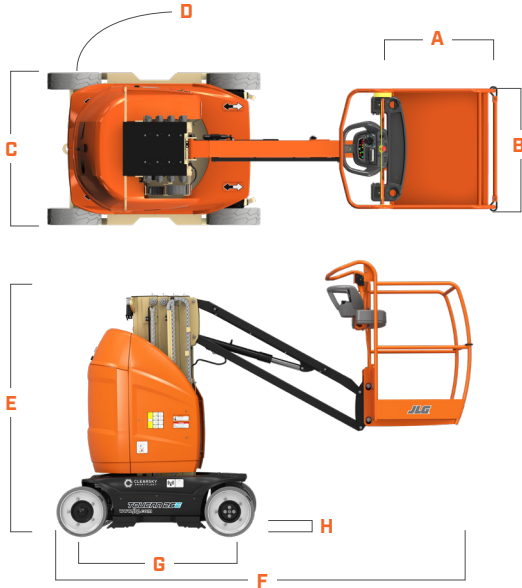

- A.** Platform Width 28-in / 0.70-m
- B.** Platform Length 36-in / 0.90-m
- C.** Machine Width 3-ft 3-in / 0.99-m
- D.** Tailswing 4.7-in / 12-cm
- E.** Machine Height 6-ft-6-in / 1.99-m
- F.** Machine Length 9-ft 3-in / 2.82-m (Drop Bar)
- G.** Wheelbase 3-ft-11-in / 1.2-m
- H.** Ground Clearance 3.9-in / 10-cm

REACH DIAGRAM

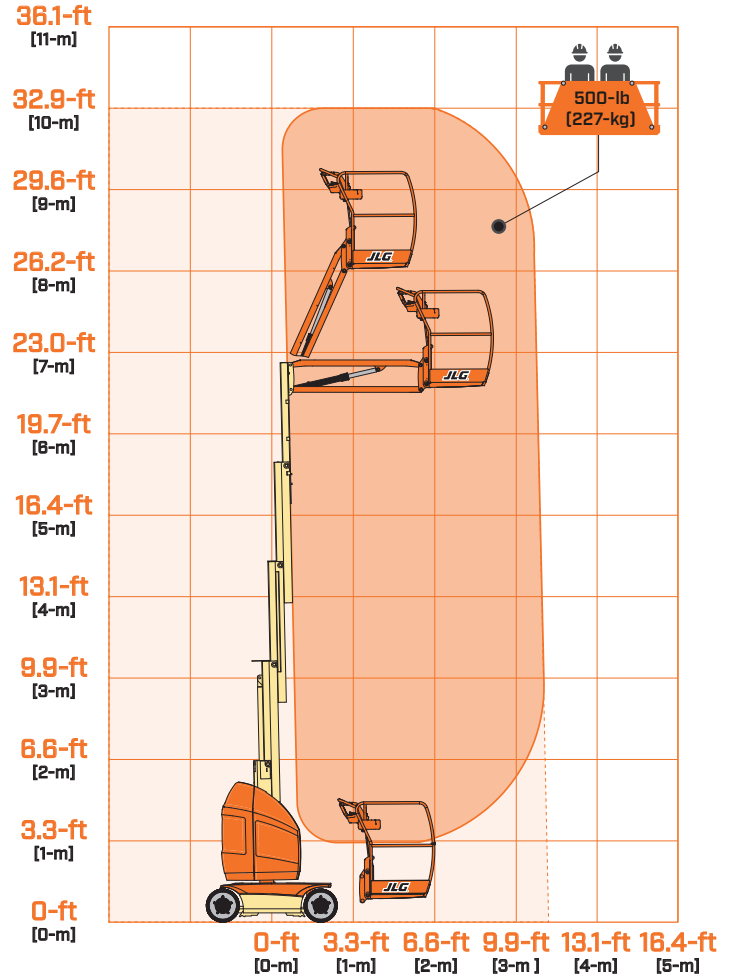

We provide coverage for one (1) full year, and cover all specified major structural components for five (5) years. Due to continuous product improvements, we reserve the right to make specification and/or equipment changes without prior notification. This machine meets or exceeds applicable ANSI and CSA requirements based on machine configuration as originally manufactured for intended applications. Please reference the serial number plate on the machine for additional information.



JLG INDUSTRIES, INC.
 Toll-free US 877-JLG-LIFT
JLG.com
 An Oshkosh Corporation Business