

# ERT4069

ELECTRIC POWERED ROUGH TERRAIN SERIES

SCISSOR LIFT



## KEY SPECS

### Platform Height

40-ft 3-in / 12.3-m

### Platform Capacity

800-lb / 363-kg

### Machine Width

69.3-in / 1.76-m

### Stowed Drive Speed

3.5 mph / 5.6 km/h

## KEY FEATURES

- Electric powered rough terrain models offer drive capability at full height, limiting unnecessary trips up and down for working professionals.
- As the largest platform size in its class, you can bring more operators and tools to the job.
- Delivers the latest technology, featuring an LCD platform control box with LiftSense technology and USB charging for next-level, real-time productivity and service communication to the operator.
- Utilizes higher part commonality and a maintenance-free 2WD AC drive system for simplified service across the rough terrain family.

## ACCESSORIES & OPTIONS

- 8 x 6V, 310 Amp Hr Batteries
- Generator Set (Kubota Stage V OC60-E4) 6hp (4.5kW)
- Genset, Range Extending
- Heavy Duty Pipe Racks
- Hydraulic Leveling Jacks (Auto Level)\*
- JLG CleanGuard Leak Containment System
- Operator Access Control
- Platform Worklights
- Second Flashing Amber Beacons - LED
- SkySense® Enhanced Detection System
- Special Hydraulic Fluids
- Special Paint
- White Noise Backup Alarm

\*Machine pictured features optional hydraulic leveling jacks.

## STANDARD SPECIFICATIONS

| Performance                    | Indoor               | Outdoor              |
|--------------------------------|----------------------|----------------------|
| Platform Height-Elevated       | 40-ft 3-in / 12.3-m  | 40-ft 3-in / 12.3-m  |
| Platform Height-Lowered        | 4-ft 10-in / 1.5-m   | 4-ft 10-in / 1.5-m   |
| Platform Capacity              | 800-lb / 363-kg      | 800-lb / 363-kg      |
| Capacity on Platform Extension | 300-lb / 136-kg      | 300-lb / 136-kg      |
| Number of Occupants            | 3                    | 2                    |
| Lift / Lower Time              | 50/48 seconds        | 50/48 seconds        |
| Maximum Drive Height           | Fully Elevated       | Fully Elevated       |
| Weight w/One Extension*        | 10,558-lb / 4,799-kg | 10,558-lb / 4,799-kg |
| Ground Bearing Pressure        | 44 psi / 3.09 kg/cm2 | 44 psi / 3.09 kg/cm2 |
| Drive Speed-Lowered            | 3.5 mph / 5.6 km/h   | 3.5 mph / 5.6 km/h   |
| Drive Speed-Raised             | 0.3 mph / 0.48 km/h  | 0.3 mph / 0.48 km/h  |
| Gradeability                   | 35%                  | 35%                  |
| Max Tilt Rating - Side-to-Side | 2.5 Degrees          | 2.5 Degrees          |
| Max Tilt Rating - Fore and Aft | 3 Degrees            | 3 Degrees            |
| Turning Radius - Inside        | 83-in / 2-m          | 83-in / 2-m          |
| Turning Radius - Outside       | 175-in / 4.44-m      | 175-in / 4.44-m      |

\* Certain options or country standard will increase weight.

## Power Source

|             |                   |
|-------------|-------------------|
| Drive (2WD) | AC Electric Drive |
| Batteries   | 8 x 6V 310 Ah     |

## Tires

|          |                                       |
|----------|---------------------------------------|
| Standard | 26-in x 12-in Foam-filled Non-Marking |
| Optional | 26 x 12 Foam-Filled Lug Tread         |
| Optional | 26 x 12 Foam Filled Turf              |

## Hydraulic System

|          |                 |
|----------|-----------------|
| Capacity | 13.2 gal / 50 L |
|----------|-----------------|

## STANDARD FEATURES

- 110V-AC Receptacle In Platform
- 2WD AC Drive System
- 23 Amp Automatic, SCR Battery Charger
- 42-in Roll-out Deck Extension
- All Motion Alarm
- ClearSky Smart Fleet™ Hardware (CS550)
- Descent Alarm
- Full Time Traction Control
- Horn
- Hourmeter
- LCD Display with LiftSense System
- LED Motion/Amber Beacon (CS550)
- Lubrication-Free Scissor Arm Bushings
- Manual Descent Pull Cable1
- Moveable, Removable Platform Console Box
- Nickel Plated Pins, Yellow Zinc-Chromate Plated Fasteners
- Oscillating Front Axle
- Pin-Less Fold Down Rail System
- Pin-based Load Sensing System
- Platform Control Box with LCD Display
- Proportional Lift and Drive
- Self-closing Gate
- Scissor Maintenance Prop
- Telematics-Ready Harness
- Tie Down Lugs
- USB Charger and Phone Holster

# ERT4069

ELECTRIC POWERED ROUGH TERRAIN SERIES

SCISSOR LIFT



## DIMENSIONS

All dimensions are approximate

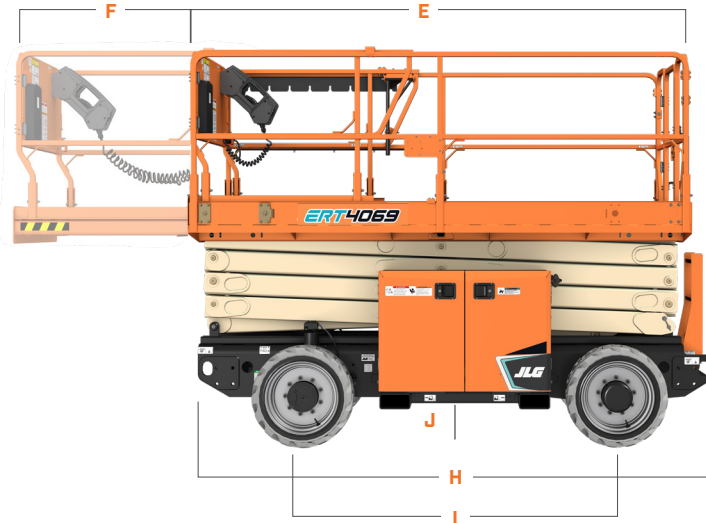
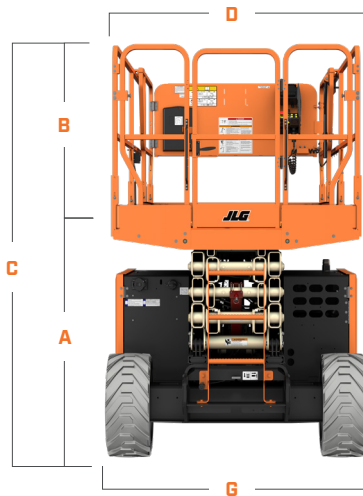

|                                     |                     |                              |                   |
|-------------------------------------|---------------------|------------------------------|-------------------|
| <b>A.</b> Platform Height – Lowered | 4-ft 10-in / 1.46-m | <b>F.</b> Platform Extension | 42-in / 1.07-m    |
| <b>B.</b> Platform Railing Height   | 44.7-in / 1.14-m    | <b>G.</b> Machine Width      | 69.3-in / 1.76-m  |
| <b>C.</b> Machine Height            | 103-in / 2.62-m     | <b>H.</b> Machine Length     | 139-in / 3.53-m   |
| <b>D.</b> Platform Width            | 63-in / 1.6-m       | <b>I.</b> Wheelbase          | 81.3-in / 2.07-m  |
| <b>E.</b> Platform Length           | 130.5-in / 3.3-m    | <b>J.</b> Ground Clearance   | 10.1-in / 25.7-cm |



We provide coverage for one (1) full year, and cover all specified major structural components for five (5) years. Due to continuous product improvements, we reserve the right to make specification and/or equipment changes without prior notification. This machine meets or exceeds applicable ANSI and CSA requirements based on machine configuration as originally manufactured for intended applications. Please reference the serial number plate on the machine for additional information.



**JLG INDUSTRIES, INC.**  
Toll-free US 877-JLG-LIFT  
[JLG.com](http://JLG.com)

An Oshkosh Corporation Business