

# X15JP

COMPACT CRAWLER

BOOM LIFT

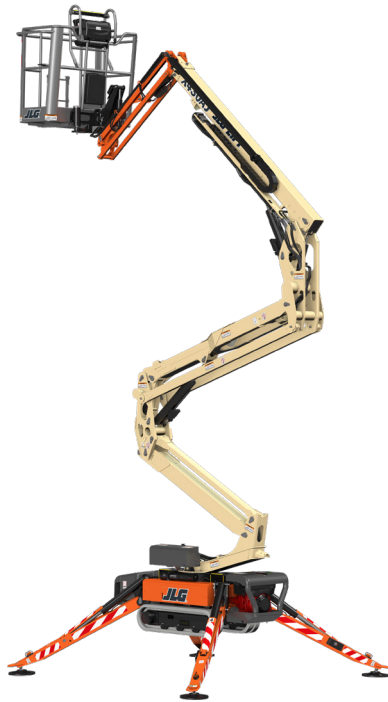

## STANDARD SPECIFICATIONS

### Performance

Platform Height	43-ft 6-in / 13.30-m
Horizontal Outreach	21-ft 7-in / 6.60-m
Platform Capacity	500-lb / 227-kg
Swing	360 Degrees Non-continuous
Platform Rotation	124 Degrees (+62, -62 Degrees)
Jib (Range of Articulation)	89 Degrees (0, -89 Degrees)
Ground Bearing Pressure (Tracks)	8.20 psi / 0.58 kg/cm <sup>2</sup>
Ground Bearing Pressure (Outriggers)	34.1 psi / 2.40 kg/cm <sup>2</sup>
Drive Speed	0.87 mph / 2.40 km/h
Max Approach / Depart Angle	20° / 36°
Gradeability	28%
Weight* (Diesel)	4,392-lb / 1,992-kg

\*Certain options or country standards increase weight

### Power

Engine: Honda iGX390	11.7 hp / 8.7 kW
Fuel Tank Capacity	1.4 gal / 5.3 L
AC Motor	120V AC / 60 HZ
Optional: 36V Lithium Ion Battery	36V / 100Ah

### Tracks

Standard	Non-marking Tracks
----------	--------------------

### Hydraulic System

Capacity	6.34 gal / 24 L
----------	-----------------

### KEY SPECS

**Platform Height**  
43-ft 6-in / 13.30-m

**Platform Capacity**  
500-lb / 227-kg

**Horizontal Outreach**  
21-ft 7-in / 6.60-m

**Overall Width  
(W/O Platform)**  
29-in / 0.75-m

### KEY FEATURES

- Best-in-class 500-lb unrestricted platform capacity.
- Environmentally friendly with standard AC powered boom functions, gas or an optional lithium-ion electrical system for emission-free operation.
- Access tight spaces and climb slopes with ease thanks to a narrow chassis and tracked wheel carriage.
- Transport with ease by a forklift or crane with forklift pockets and lifting eyes, and fits through standard doorway.

## STANDARD FEATURES

- 110V-AC receptacle in Platform
- Below Grade Capability
- Caster Platform Wheels
- Color Remote and Ground Panel Provides Diagnostics
- Flashing Amber Beacon
- Fork Pockets and Lifting Hooks
- Fully Synthetic Biodegradable Hydraulic Fluid
- Large Teflon® Outrigger Pads
- Multi-Position Outriggers
- One-touch Outrigger Leveling
- Patented Quick Disconnect Platform
- QuikStik®
- SkyGuard SkyLine™
- Standard Air/Water Line

## ACCESSORIES & OPTIONS

- Black Deep-Tread Tracks
- Platform, Single-Person 31 x 24-in

# X430AJ

COMPACT CRAWLER

BOOM LIFT



## DIMENSIONS

All dimensions are approximate

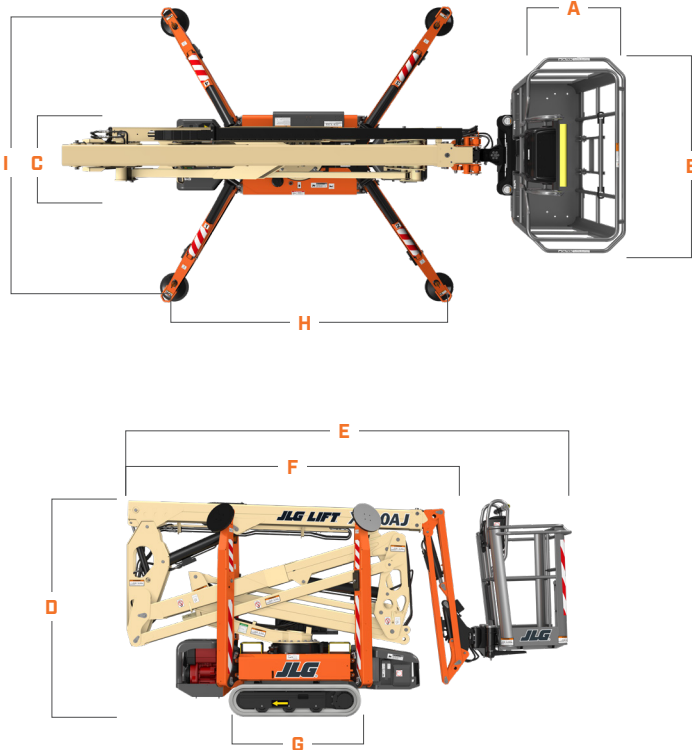

<b>A.</b> Platform Width	30-in / .76-m
<b>B.</b> Platform Length	52-in / 1.34-m
<b>C.</b> Machine Width	29-in / 75-cm
<b>D.</b> Machine Height	6-ft 6-in / 1.98-m
<b>E.</b> Machine Length	13-ft 2-in / 4.02-m
<b>F.</b> Machine Length Without Platform	11-ft 2-in / 3.40-m
<b>G.</b> Track length	4-ft 1-in / 1.24-m
<b>H.</b> Outrigger Footprint Length	9-ft 8-in / 3.0-m
<b>I.</b> Outrigger Footprint Width	9-ft 8-in / 3.0-m
<b>J.</b> Outrigger Pad Diameter	11.8-in / 30-cm

## REACH DIAGRAM

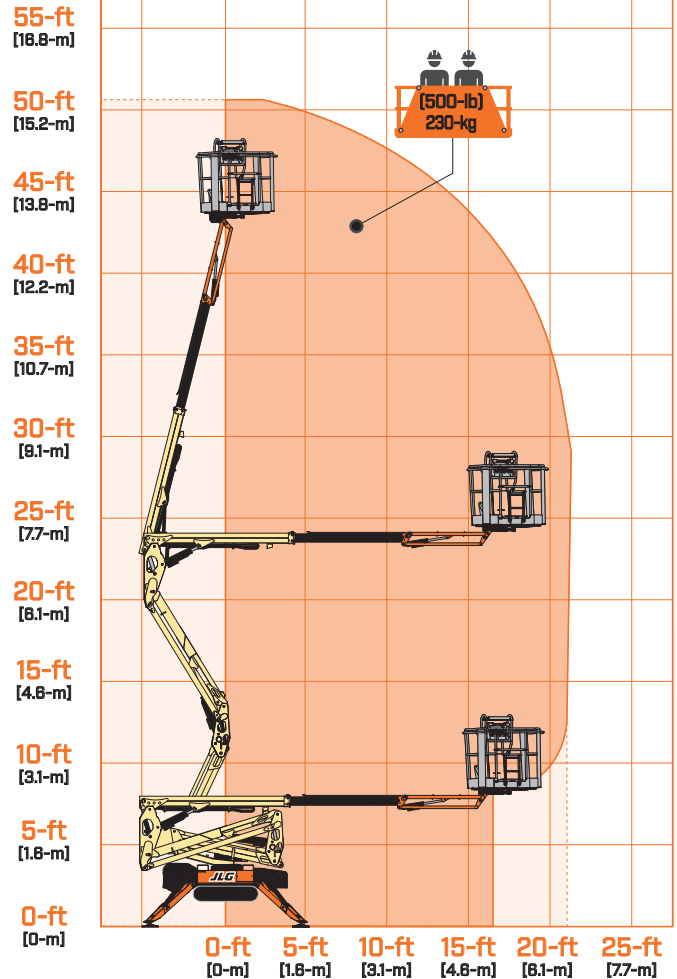

We provide coverage for one (1) full year, and cover all specified major structural components for five (5) years. Due to continuous product improvements, we reserve the right to make specification and/or equipment changes without prior notification. This machine meets or exceeds applicable ANSI and CSA requirements based on machine configuration as originally manufactured for intended applications. Please reference the serial number plate on the machine for additional information.



**Oshkosh-JLG (S) Technology Equipment Pte Ltd**  
 32 Jalan Kilang Barat  
 Kewalram House, 159364  
 Singapore  
 Phone: +65 6591 9368