

860SJ HC3

TELESCOPIC HI-CAPACITY BOOM LIFT

BOOM LIFT



**3 CAPACITY ZONES - EACH
RATED FOR OCCUPANTS +
TOOLS/MATERIALS**

HC3

KEY SPECS

Platform Height
86-ft / 26.21-m

Drive Speed
3.5 mph / 5.6 km/h

Horizontal Outreach
74-ft 8.9-in / 22.78-m

Platform Capacity
Restricted: 750/1,000-lb / 340/454-kg
Unrestricted: 500-lb / 227-kg

KEY FEATURES

- Utilizes three working zones for enhanced capacity; up to three workers and tools can fit onto the platform.
- Delivers a zero calibration automatic load sensing system that eliminates the need to use external weights to calibrate the machine.
- Upgraded light panel for more visibility in the sun and chassis tilt alarm that alerts the operator when the machine is on a slope that exceeds 4 Degrees.
- Available accessories and options provide the flexibility to upfit the machine to meet unique job requirements.

ACCESSORIES & OPTIONS

- 1/2-in Air Line to Platform
- AC Generator, 2500W or 4000W
- Accessory Packages
 - SkyGlazier® Package
 - SkyPower® Package
 - SkyWelder® Package
- Arctic Package¹
- Bolt On Fall Arrest System
- Cold Weather Package²
- Hostile Environment Package³
- Light Package
- Platform Mesh to Mid or Top Rail
 - Aluminum or Plastic
- Platforms
 - Drop Bar, 30 x 36-in, 30 x 48-in, 30 x 60-in, 36 x 72-in, 36 x 96-in
 - Fall Arrest, Rear Entry, 36 x 72-in, 36 x 96-in
 - Inward Self-Closing Swing Gate, 30 x 48-in, 30 x 60-in, 36 x 72-in, 36 x 96-in
- Tri-Entry, Drop Bar or Swing Gate, 36 x 72-in, 36 x 96-in
- SkySense® Enhanced Detection System
- Soft Touch System
- Storage Tray - Center or Corner

STANDARD SPECIFICATIONS

Performance

Platform Height (Elevated)	86-ft / 26.21-m
Horizontal Outreach	74-ft 8.9-in / 22.78-m
Swing	360 Degrees Continuous
Platform Capacity (Restricted)	750/1,000-lb / 340/454-kg
Platform Capacity (Unrestricted)	500-lb / 227-kg
Platform Rotator	180 Degrees Hydraulic
Jib Length	6-ft / 1.83-m
Jib Range of Articulation	131 Degrees (+70, -60)
Weight*	38,040-lb / 17,255-kg
Max. Ground Bearing Pressure	104.6 psi / 7.4 kg/cm ²
Drive Speed	4.13-mph / 6.65 km/h
Gradeability 2WD Gradeability 4WD	25% / 45%
Tilt Cut Out	4 Degrees
Turning Radius (Inside) Turning Radius (Outside)	14-ft 7.7-in / 4.5-m / 21-ft 7-in / 6.6-m

Engine

Dual Fuel – Ford-MSG425-DF	84 hp / 62.6 kW
Diesel Fuel – Deutz D2.9L4 Tier 4 Final	67 hp / 50 kW
Diesel Fuel – Deutz TD2.9L4 T4i	50kW
Fuel Tank Capacity	31 gal / 117.35 L

Tires

Standard	Foam Filled, 15-625(24.5)
Optional	Foam Filled Non-Marking, 18-625 Foam Filled, 18-625(24.5) Foam Filled, Turf & Sand, 41x18LLx22.5

Hydraulic System

Capacity	48 gal / 181.7 L
Pump	Fixed Displacement Gear

STANDARD FEATURES

- 4 Degree Tilt Alarm / Indicator Light
- 12V-DC Auxiliary Power
- 110V-AC Receptacle in the Platform
- 180 Degree Hydraulic Platform Rotator
- ClearSky Smart Fleet™ Hardware (CS550)**
- Control ADE® System
- Glow Plugs (Diesel Engines)
- Horn
- Hourmeter
- Hydrostatic Drive
- Improved Multi-Function Controls
- Interactive Display at Ground Controls
- LED Motion / Amber Beacon (CS550)**
- Lifting / Tie Down Lugs
- Motion Alarm
- Oscillating Axle
- Platform Console Machine Status Light Panel***
- Proportional Controls
- SkyGuard SkyLine™
- Swing-Out Engine Tray

*Certain Options or Country Standards Increase Weight.

**Standard Beacon and ClearSky Smart Fleet Hardware Availability Varies by Model Throughout 2023.

***Provides Indicator Lights at Platform Control Console for System Distress, Low Fuel, Degree Tilt Light and Foot Switch Status.

- Includes arctic hydraulic hoses (drive and steer only) and main boom cable, arctic hydraulic oil, extreme cold engine oil, fuel conditioner, engine block heater, battery blanket, glow plugs, hydraulic tank heater, and oversized footswitch.
- Includes battery blanket, hydraulic tank heater, block heater.
- Includes console cover, boom wipers and cylinder bellows.

Note: Some options may increase lead time, and some option combinations may not be available. Additional accessories and options available via JLG Aftermarket.

860SJ HC3

TELESCOPIC HI-CAPACITY BOOM LIFT

BOOM LIFT



DIMENSIONS

All dimensions are approximate

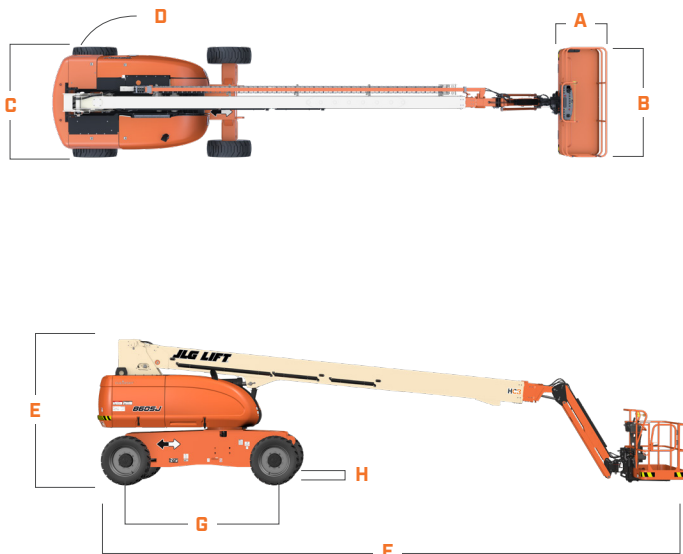

- A. Platform Width 36-in / 91-cm
- B. Platform Length 96-in / 2.44-m
- C. Machine Width 8-ft 2-in / 2.49-m
- D. Tailswing 4-ft 8-in / 1.42-m
- E. Machine Height 9-ft 8.1-in / 2.95-m
- F. Machine Length 40-ft / 12.19-m
- G. Wheelbase 10-ft / 3.05-m
- H. Ground Clearance 11-in / 28-cm

REACH DIAGRAMS

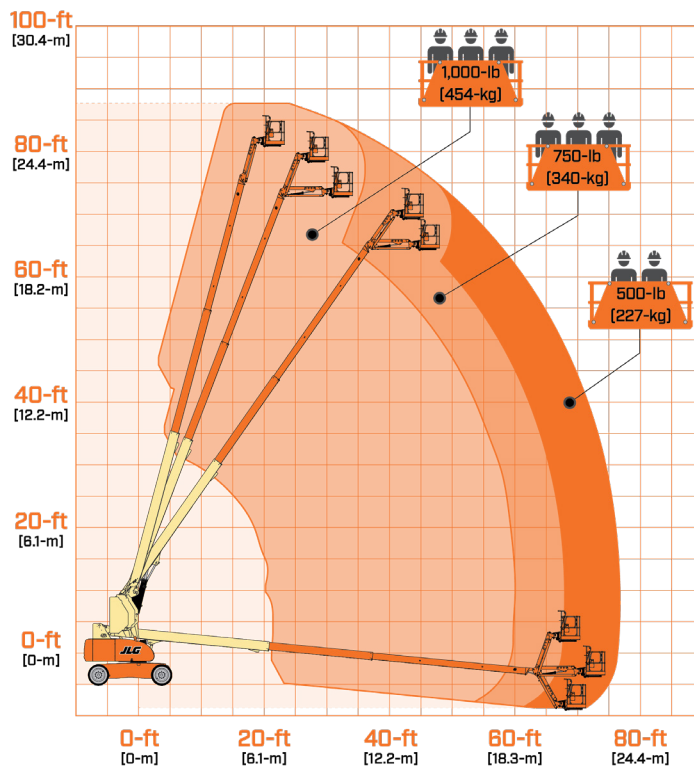

We provide coverage for one (1) full year, and cover all specified-major structural components for five (5) years. Due to continuous product improvements, we reserve the right to make specification and/or equipment changes without prior notification. This machine meets or exceeds applicable ANSI and CSA requirements based on machine configuration as originally manufactured for intended applications. Please reference the serial number plate on the machine for additional information.



Oshkosh-JLG (S) Technology Equipment Pte Ltd
 32 Jalan Kilang Barat
 Kewalram House, 159364
 Singapore
 Phone: +65 6591 9368