

# EC600SJ

ELECTRIC BOOM

BOOM LIFT



## KEY SPECS

**Platform Height**  
60-ft 3-in / 18.36-m

**Horizontal Outreach**  
43-ft 3-in / 13.18-m

**Drive Speed**  
3.0 mph / 4.8 km/h

**Platform Capacity**  
500-lb / 227-kg

## KEY FEATURES

- Peak productivity with 60-ft 3-in platform height and 43-ft 3-in horizontal outreach.
- Produces zero emissions, emits reduced sound and utilizes non-marking tires.
- Achieve maximum maneuverability by moving over uneven surfaces with Automatic Traction Control.
- Achieve optimum productivity with longer duty cycles.

## ACCESSORIES & OPTIONS

- AGM Batteries, 390 amp-hr
- Bolt-on Fall Arrest System
- Hostile Environment Kit<sup>1</sup>
- Inverter - 1200W or 3000W
- Light Package<sup>2</sup>
- Platform Mesh to Mid or Top Rail<sup>3,4</sup>
  - Aluminum or Plastic
- Platforms
  - Drop Bar, 30 x 36-in, 30 x 48-in, 30 x 72-in
- Fall Arrest, Rear Entry, 30 x 60-in, 36 x 72-in
- Inward Self-Closing Swing Gate, 30 x 48-in, 30 x 72-in, 36 x 72-in
- Tri-Entry Drop Bar or Swing Gate, 36 x 72-in
- SkySense<sup>®</sup> Enhanced Detection System<sup>5</sup>
- Soft Touch System<sup>4</sup>
  - Self-Closing Swing Gate, Drop Bar or Fall Arrest<sup>6</sup>, 36 x 72-in
- Storage Tray - Center or Corner
- UL<sup>®</sup> EE Rating

1. Includes Console Cover, Boom Wipers and Cylinder Bellows.

2. Includes Head and Tail Lights, Platform Worklight.

3. Requires Self-Closing Gate.

4. Not Compatible with Bolt On Fall Arrest, Platform Mesh, Platform Rail Extensions, SkySense, or Soft Touch (Excludes Option Noted).

5. Not Compatible with Bolt On Fall Arrest.

6. Requires Fall Arrest Platform, Rear Entry.

Additional Accessories and Options Available Via JLG Aftermarket.

## STANDARD SPECIFICATIONS

### Performance

Platform Height	60-ft 3-in / 18.36-m
Horizontal Outreach	43-ft 3-in / 13.18-m
Swing	400 Degrees Non-Continuous
Platform Capacity	500-lb / 227-kg
Platform Rotator	180 Degrees Hydraulic
Jib Range of Articulation (Vertical)	145 Degrees (+75, -70)
Weight*	16,710-lb / 7,580-kg
Max. Ground Bearing Pressure	52 psi / 3.7 kg/cm <sup>2</sup>
Drive Speed	3.0 mph / 4.8 km/h
Gradeability (2WD)	30%
Gradeability (4WD)	45%
Turning Radius Inside (2WS/4WS)	4-ft / 1.22-m
Turning Radius Outside (2WS/4WS)	15-ft 2.5-in / 4.64-m

### Power Source

Electrical System	48V DC
Batteries	8 x 6V, 415 amp-hr
Drive Motors	Dual Electric Traction

### Tires

Standard	36 x 14-22.5 Non-Marking Foam-filled
----------	--------------------------------------

### Hydraulic System

Capacity	15 gal / 56.78 L
Motor/pump	Series Wound Motor/Gear Pump

## STANDARD FEATURES

- 4 Degree Tilt Cut-out
- 6-ft (1.83-m) Articulating Jib
- 110V-AC GFI Receptacle in the Platform
- All Motion Alarm
- Automatic Traction Control
- Battery Condition Indicator
- ClearSky Smart Fleet<sup>™</sup> Hardware (CS550)\*\*
- Hourmeter
- LED Motion/Amber Beacon (CS550)\*\*
- Lifting/Tie Down Lugs
- Load Sensing System
- Manual Descent
- Oscillating Axle
- Platform Console Machine Status Light Panel\*\*\*
- Removable Battery Box
- SCR Automatic Battery Charger
- SkyGuard SkyLine<sup>™</sup>
- Tilt Light and Alarm

\*Certain options or country standards increase weight.

\*\*Standard beacon and ClearSky Smart Fleet hardware availability varies by model throughout 2023.

\*\*\*Provides indicator lights at platform control console for system distress, low fuel, degree tilt light and foot switch status.

## DIMENSIONS

All dimensions are approximate

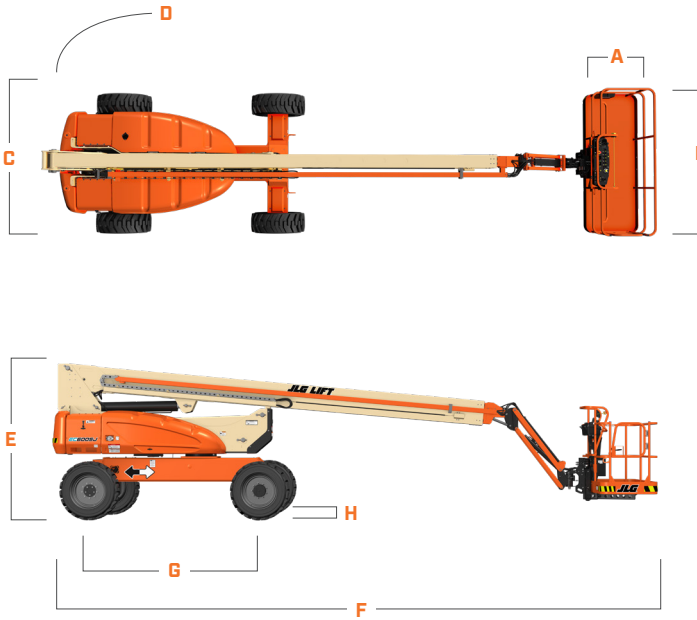

## REACH DIAGRAM

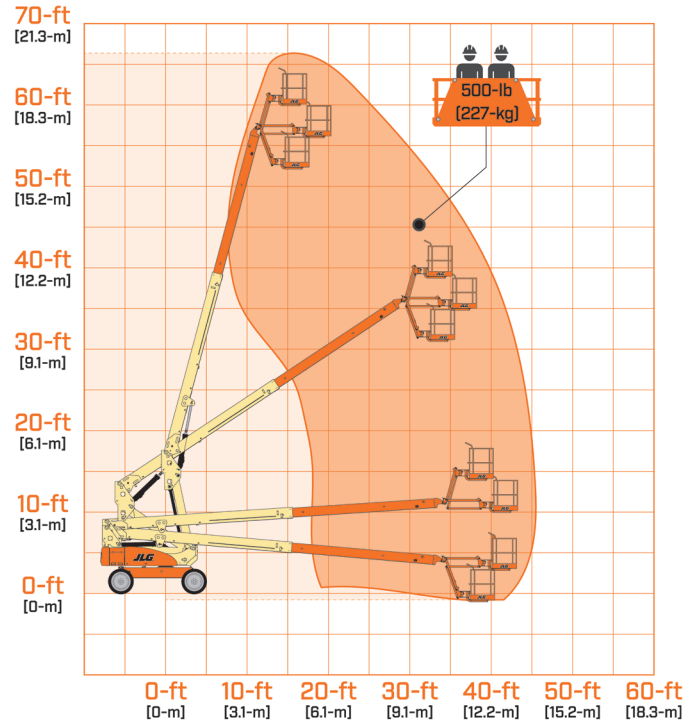

- A. Platform Width 30-in / 76-cm
- B. Platform Length 72-in / 1.83-m
- C. Machine Width 7-ft 11-in / 2.41-m
- D. Tailswing 4-ft / 1.22-m
- E. Machine Height 8-ft 4-in / 2.54-m
- F. Machine Length 30-ft 9-in / 9.37-m
- G. Wheelbase 9-ft / 2.74-m
- H. Ground Clearance 10-in / 26-cm



We provide coverage for one (1) full year, and cover all specified major structural components for five (5) years. Due to continuous product improvements, we reserve the right to make specification and/or equipment changes without prior notification. This machine meets or exceeds applicable ANSI and CSA requirements based on machine configuration as originally manufactured for intended applications. Please reference the serial number plate on the machine for additional information.



**Oshkosh-JLG (S) Technology Equipment Pte Ltd**  
 32 Jalan Kilang Barat  
 Kewalram House, 159364  
 Singapore  
 Phone: +65 6591 9368