

# ES2632

## ELECTRIC SCISSOR LIFT

SCISSOR LIFT



### KEY SPECS

#### Platform Height

Indoor: 7.77 m  
Outdoor: 6.4 m

#### Number of Occupants

Indoor: 2  
Outdoor: 1

#### Platform Capacity

Indoor: 230 kg  
Outdoor: 125 kg

#### Stowed Drive Speed

4.8 km/h

### KEY FEATURES

- Delivers narrow width to fit through most standard doorways and tight aisles.
- Reduce operating costs with DC electric drive and integrated components containing reduced hydraulic hoses and hydraulic fittings on the entire machine. Meaning, increased uptime as well as fewer leaks and service calls.
- Work in sensitive areas with optional CleanGuard leak containment system.
- Features a standard USB charger and phone holster, improving the operator experience while delivering a high degree of commonality with other JLG® scissors to simplify service.

### ACCESSORIES & OPTIONS

- Dual Fold Down Handrails
- Drive Motor Covers
- Platform work-lights
- 6V- 220A/hr Flooded Lead Acid batteries
- Clean Guard
- SkySense Level 1
- SkySense Level 2
- All motion alarm
- Descent alarm
- Panel Carrier
- Inboard pipe racks
- Workstation
- White Noise Alarm
- Electricians' Package \*
- Amber beacon light (dual)
- Plugs & Sockets
- Anti vandalism package
- MDI (Ground)

### STANDARD SPECIFICATIONS

#### Performance

Working Height (Indoor/ Outdoor)	9.77 m / 8.4 m
Platform Height - Elevated (Indoor/ Outdoor)	7.77 m / 6.4 m
Platform Capacity - Indoor	230 kg
Platform Capacity - Outdoor	125 kg
Number of Operators	2 for indoor / 1 for outdoor
Capacity on Optional Deck Extension	120 kg
Lift/Lower Time (No Load)	33 / 36 seconds
Lift/Lower Time (Rated Load)	39 / 29 seconds
Maximum Drive Height	Full elevation (Indoor mode)
Machine weight *	1996 kg
Maximum Ground Bearing Pressure	7.52 kg/cm <sup>2</sup>
Drive Speed - Lowered	4.8 km/h
Drive Speed - Elevated	0.8 km/h
Gradeability	25% (14°)
Turning Radius - Inside	Zero
Turning Radius - Outside	2.09 m
Max Tilt Rating (Side-to-Side)	1.5°
Max Tilt Rating (Fore and Aft)	3.5°

\* Certain options or country standards may increase weight and/or dimensions.

#### Power

Drive Motors	24V DC
Hydraulic Pump Motor	24V DC / 3 KW
Batteries	AGM 4 x 6V 213 A/hr
Charger (120/240V - 50/60HZ)	27 Amp - Automatic

#### Tires

Tires (Non-Marking Solid)	406 mm x 127 mm
---------------------------	-----------------

#### Brakes

Electric / friction - front wheels

#### Hydraulic System

Capacity	18 L
----------	------

### STANDARD FEATURES

- 0.86 m roll-out deck extension
- Fold Down Handrails
- Swing- out gate
- Removable platform console box
- Lanyard attach points
- Full proportional drive joystick control with integral thumb steer switch
- Proportional lift/lower speed control
- Joystick enable for lift and drive
- Load sensing system
- USB Charger & Phone Holder
- Diamond Tread Steel Deck
- 4 x 6V 213 A/hr AGM Batteries
- Programmable "Personality" settings
- On-board self-diagnostic testing
- Swing-out battery/electrical compartment doors
- 27 amp automatic battery charger
- Battery Charger (DELTA-Q, 650W, CAN)
- Dual motor direct electric front wheel drive & steer
- Dual wheel automatic brakes
- Emergency brake release
- Active Pothole protection system
- AC cable to platform
- Analyzer Port for Diagnostics
- Battery condition indicator
- Hour meter
- Lubrication free scissor arm bushings
- Manual descent
- Horn
- Removable Ladder
- Lifting lugs
- Greaseless Kingpin Joints
- Variable tilt sensing (side-to-side)
- Slope alarm and light
- Tie down lugs
- Fork lift pockets
- Amber beacon light
- Clearsky SMART FLEET connectivity beacon - subscription through On Line Express

\* Includes workstation without 12 V outlet, pipe racks, vice and electricians tree.

# ES2632

## ELECTRIC SCISSOR LIFT

SCISSOR LIFT



### DIMENSIONS

All dimensions are approximate

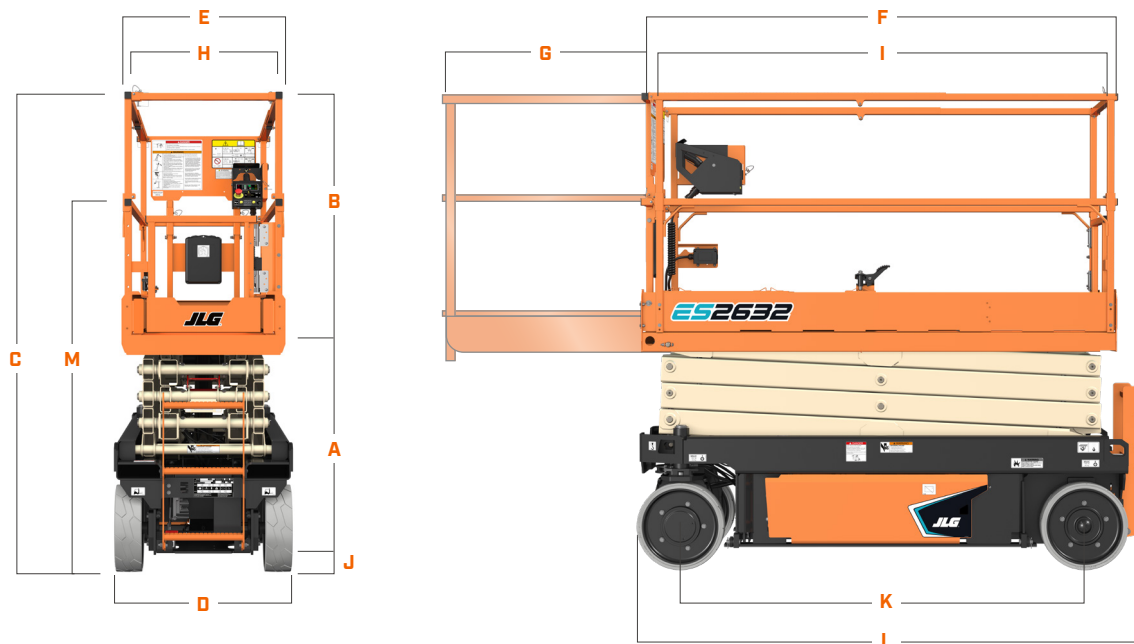

<b>A.</b> Platform Height – Lowered	1.10 m	<b>H.</b> Platform Width, Internal	0.64 m
<b>B.</b> Platform Railing – Height	1.10 m	<b>I.</b> Platform Length, Internal	2.10 m
<b>C.</b> Stowed Height	2.22 m	<b>J.</b> Ground Clearance	98 mm
<b>D.</b> Machine Width	0.81 m	<b>K.</b> Wheelbase	1.88 m
<b>E.</b> Platform Width, External	0.77 m	<b>L.</b> Machine Length	2.40 m**
<b>F.</b> Platform Length, External	2.30 m	<b>M.</b> Stowed Height (Rails Folded)	1.77 m*
<b>G.</b> Deck Extension	0.86 m		

\* Folding rails are standard in CE specification.  
\*\* Including ladder

#### IMPORTANT

JLG is continually researching and developing products and reserves the right to make modifications without prior notice. All data in this document is indicative. Certain options or country standards will increase weight. Specifications may change to meet country standards or with the addition of optional equipment.

Due to continuous product improvements, JLG Industries reserves the right to make specification and/or equipment changes without prior notification.



**JLG EMEA BV**  
Polaris Avenue 63  
2132 JH Hoofddorp  
The Netherlands  
Tel.: +31 (0)23 565 5665  
[www.jlg.com](http://www.jlg.com)

An Oshkosh Corporation Company