



KEY SPECS

Platform Height

100-ft / 30.48-m

Up and Over Height

56-ft 5-in / 17.2-m

Horizontal Outreach

54-ft 2-in / 16.50-m

Platform Capacity

500-lb / 227-kg - Unrestricted, 2 Occupants
660-lb / 300-kg - Restricted, 2 Occupants

KEY FEATURES

- Class-leading 56-ft up and over work envelope and 54-ft horizontal outreach with 500-lb unrestricted, 660-lb restricted, platform capacity.
- Different power configurations available with standard diesel engine, optional lithium-ion battery or optional bi-energy.
- User friendly with one-touch, self-leveling, multi-position outriggers.
- Transport with ease by a forklift or crane with forklift pockets and lifting eyes, and fits through double doorway.

ACCESSORIES & OPTIONS

- Bi-Energy Power Option - Includes Diesel Engine and Lithium-Ion Battery
- Black Deep-Tread Tracks

STANDARD SPECIFICATIONS

Performance

Platform Height	100-ft / 30.48-m
Working Height	106-ft / 32.30-m
Max Working Horizontal Outreach	54-ft 2-in / 16.50-m
Up and Over Height	56-ft 5-in / 17.2-m
Platform Capacity - Unrestricted	500-lb / 227-kg - 2 Occupants Max
Platform Capacity - Restricted	660-lb / 300-kg - 2 Occupants Max
Swing	360 Degrees Non-continuous
Jib (Range of Articulation)	180 Degrees (+85, -95 Degrees)
Travel Speed (Diesel)	1.1 mph / 1.8 km/h
Travel Speed (Lithium Ion)	.8 mph / 1.3 km/h
Max Approach Angles: Front	18 Degrees (33%)
Max Approach Angles: Rear	16 Degrees (29%)
Max Stabilization Slope	13 Degrees
Gradeability	28%
Ground Bearing Pressure (Tracks)	11.3 psi / .79 kg/cm ²
Ground Bearing Pressure (Outriggers)	58 psi / 4.1 kg/cm ²

Outrigger Footprint (From Outer Edge):

Total Stabilization Area	18-ft 2-in x 16-ft 5-in / 5.49 x 5-m
Reduced Stabilization Area	22-ft x 12-ft 2-in / 6.71 x 3.71-m
Weight (Diesel)*	17,230-lb / 7,815-kg
Weight (Lithium Ion)*	17,273-lb / 7,835-kg
Weight (Bi-Energy)*	17,538-lb / 7,955-kg

*Certain options or country standards increase weight

Power

Diesel Engine: Kubota D902	21.6 hp / 16.1 kW
Fuel Tank Capacity (Diesel)	6.6 gal / 25 L
Electric-motor	380V AC / 50 HZ, 11 kW
Optional: 64V Lithium Ion Battery	64V, 300 Ah / 19.2 kW

Tracks

Standard	Non-marking Tracks
----------	--------------------

Hydraulic System

Capacity	21 gal / 80 L
----------	---------------

STANDARD FEATURES

- 110V-AC receptacle in Platform
- Below Grade Capability
- Caster Platform Wheels
- Color Remote and Ground Panel Provides Onboard Diagnostics
- Flashing Amber Beacon
- Fork Pockets and Lifting Hooks
- Fully Synthetic Biodegradable Hydraulic Fluid
- Large Teflon® Outrigger Pads
- Multi-Position Outriggers
- One-touch Outrigger Leveling
- Patented Quick Disconnect Platform
- SkyGuard SkyLine™
- Standard Air/Water Line

X1000AJ

COMPACT CRAWLER

BOOM LIFT



DIMENSIONS

All dimensions are approximate

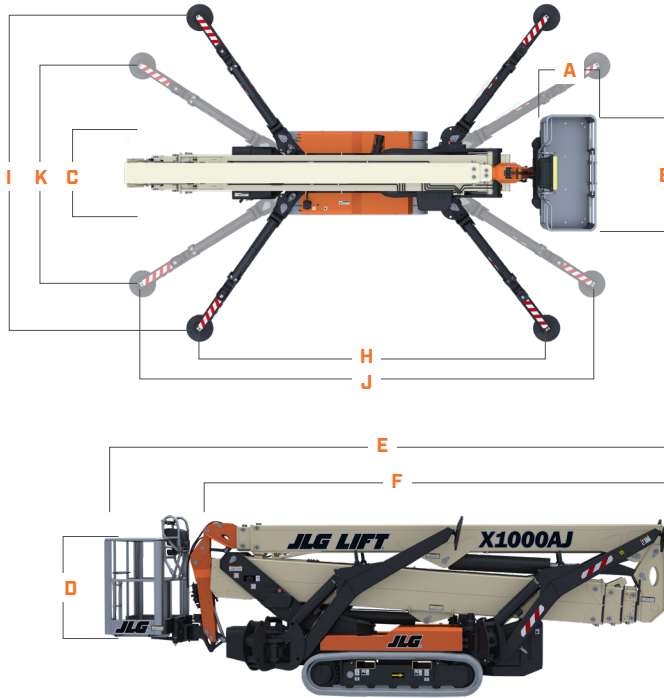

A. Platform Width	28-in / 71-cm
B. Platform Length	63-in / 1.60-m
C. Machine Width	47-in / 1.19-m
D. Machine Height	6-ft 6-in / 1.98-m
E. Machine Length	21-ft 3-in / 6.48-m
F. Machine Length Without Platform	19-ft 3-in / 5.80-m
G. Track length	6-ft 10-in / 2.08-m
H. Outrigger Footprint - Length	18-ft 2-in / 5.49-m
I. Outrigger Footprint - Width	16-ft 5-in / 5-m
J. Outrigger Footprint - Narrow Length	22-ft / 6.71-m
K. Outrigger Footprint - Narrow Width	12-ft 2-in / 3.71-m
L. Outrigger Pad Diameter	15.7-in / 40-cm

REACH DIAGRAM

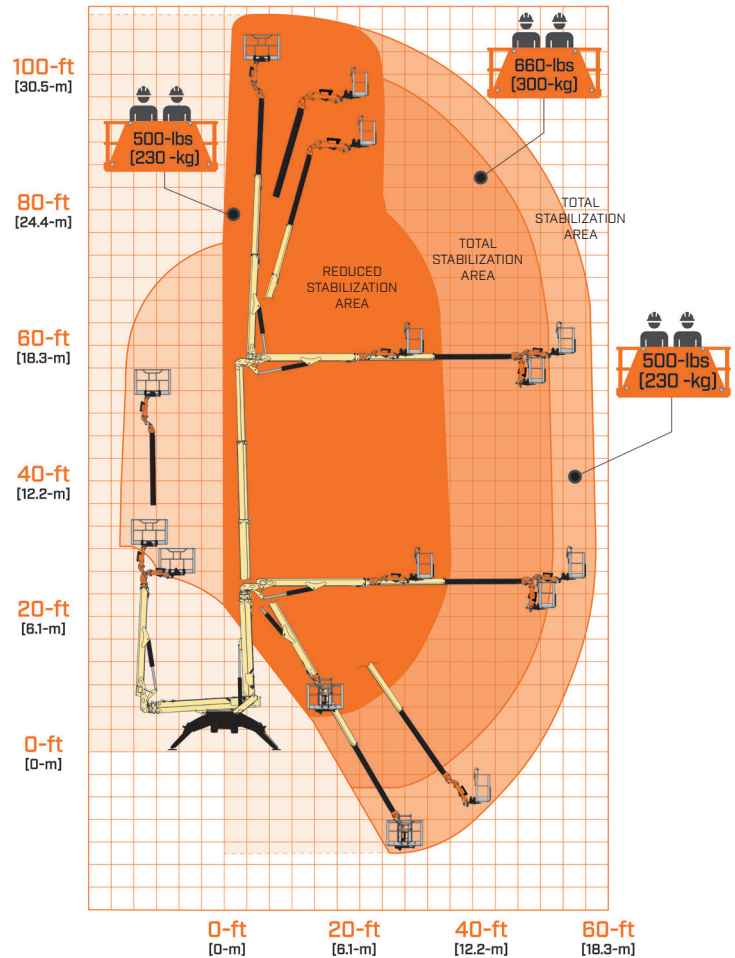

We provide coverage for one (1) full year, and cover all specified-major structural components for five (5) years. Due to continuous product improvements, we reserve the right to make specification and/or equipment changes without prior notification. This machine meets or exceeds applicable ANSI and CSA requirements based on machine configuration as originally manufactured for intended applications. Please reference the serial number plate on the machine for additional information.



JLG INDUSTRIES, INC.
Toll-free US 877-JLG-LIFT
JLG.com

An Oshkosh Corporation Business