

TOUCAN 8E-L

ARTICULATING HI-CAPACITY



KEY SPECS

Platform Capacity

200 kg Inside
 200 kg Outside

Overall Width

0.99 m

Platform Size XL (L x W)

0.85 x 0.92 m

Overall length of the XL platform

2.10 m

KEY FEATURES

- Environmentally friendly, silent and emission free model with the maintenance free AGM batteries
- Maximize productivity with the bigger platform allowing to carry 2 people
- Reach where others can't reach with the extended up and over of 5.08 m
- Get into more places with very compact stowed dimensions

ACCESSORIES & OPTIONS

- 1.10 m x 0.90 m (Lx W) XL platform
- 8 mm air line to platform
- Acoustic alarm
- Food compatible hydraulic fluid
- Low temperature hydraulic fluid
- Plugs & Sockets *
- LED platform work lights
- Control panel protection cover

STANDARD SPECIFICATIONS

Performance

Working height	8.20 m
Platform height	6.20 m
Working outreach **	2.65 m
Up and over height	5.08 m
Swing (not continuous)	345°
Platform capacity ***	200 kg
Jib - overall length	1.17 m
Jib - range of articulation	112° (+45° / -67°)
Machine weight *	1,860 kg
Maximum ground bearing pressure	15,9 kg/cm ²
Drive speed - lowered	5.5 km/h
Drive Speed - elevated	0.75 km/h
Turning radius (outside)	0.55 m
Turning radius (inside)	1.99 m
Gradeability	25%
Break over angle	25%

* Certain options or country standards may increase weight and/or dimensions.

** Incl. 0.65 m outreach beyond platform

*** Capacity shown is maximum 2 persons indoor and 1 person outdoor (12,5 m/s wind speed)

Power Source

Electrical system	24V DC
Batteries (AGM)	24 V - 213 A/hr
Drive motors	Dual AC motors
Charger	24V - 27A

Hydraulic System

Capacity	7.5 L
Electrical (pump) motor	3kW 24V DC

Tyres

Tyres (non-marking solid)	406 x 125 mm
---------------------------	--------------

STANDARD FEATURES

- 0.85 m x 0.90 m (L x W) steel platform
- Slide bar rear entry
- Full proportional drive and slew joystick control with integral thumb steer switch
- Mini joysticks provide proportional mast and jib lift/lower functions (and telescope on 12 m models)
- 1.17 m articulating jib
- Function enable with enlarged LCD function status display
- Load sensing system
- AC power cable to platform
- Large tool tray
- Two wheel direct electric drive
- Brushless AC drive motors
- 24V 180 A/hr sealed AGM batteries
- On-board 110V/230V HF battery charger
- Powered battery fill
- Auto power save when idle
- Low charge function cut-out
- On-board diagnostics with integral display
- Automatic rear wheel brakes
- Sculptured polyester hoods
- Heavy duty steel roller mast with 345° rotation
- Chain slack detection system
- 2.5 degree tilt alarm and indicator light
- 406 x 125 solid non-marking tyres
- Passive pothole protection system
- 0.99 m wide frame
- Lifting /tie down rings
- Ground control selector switch with key lock
- Battery discharge indicator
- Hour meter
- Horn
- Drive orientation system
- Lanyard anchor points
- Xenon strobe light
- Manual descent system
- Clearsky SMART FLEET connectivity module - Subscription through On Line Express
- Skyline Skyguard active system

* Included with circuit breaker on AC cable to platform option. NB 110V or 230V power must be specified

TOUCAN 8E-L

ARTICULATING HI-CAPACITY



DIMENSIONS

All dimensions are approximate

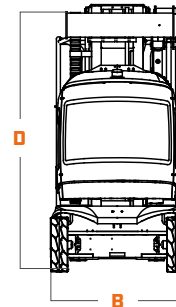
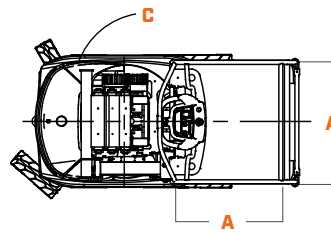
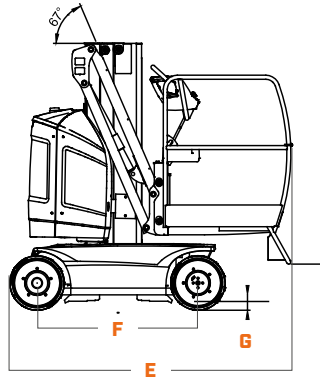

- A. Platform Size 0.85 x 0.92 m
- B. Overall Width 0.99 m
- C. Tailswing (working condition) 17 cm

- D. Stowed Height 1.99 m
- E. Stowed Length 2.10 m
- F. Wheelbase 1.20 m
- G. Ground Clearance 10 cm

REACH DIAGRAM

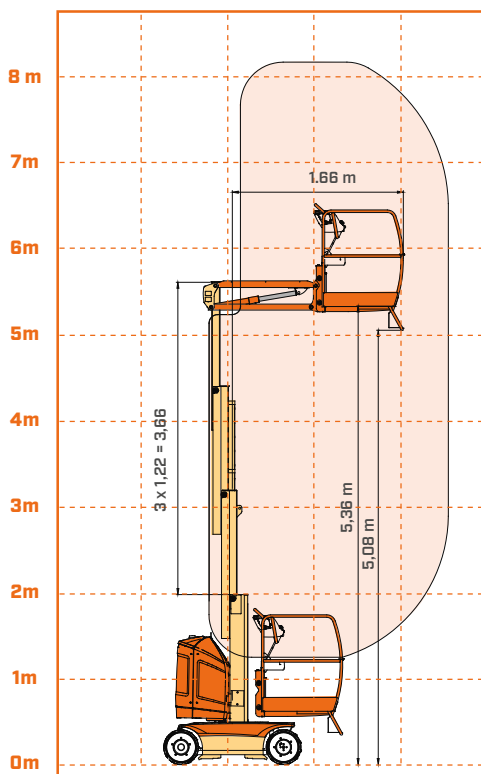

IMPORTANT

JLG is continually researching and developing products and reserves the right to make modifications without prior notice. All data in this document is indicative. Certain options or country standards will increase weight. Specifications may change to meet country standards or with the addition of optional equipment.

Due to continuous product improvements, JLG Industries reserves the right to make specification and/or equipment changes without prior notification.



JLG EMEA BV
 Polaris Avenue 63
 2132 JH Hoofddorp
 The Netherlands
 Tel.: +31 (0)23 565 5665
www.jlg.com

An Oshkosh Corporation Company