

H800AJ HYBRID

ARTICULATING BOOM LIFT



Performance

Platform Height	80 ft	24.38 m
Horizontal Outreach	51 ft 10 in.	15.8 m
Up and Over Height	32 ft 1 in.	9.78 m
Swing	360 Degrees Continuous	
Platform Capacity	500 lb	227 kg
Platform Rotator	180 Degrees Hydraulic	
Jib Range of Articulation	130 Degrees (+70, -60)	
Weight	35,520 lb	16,110 kg
Drive Speed Lowered	3.45 mph	5.55 km/h
Drive Speed Elevated	0.27 mph	0.43 km/h
Gradeability 4WD	45%	
Axle Oscillation	8 in.	20.4 cm
Ground Bearing Pressure	76 psi	5.3 kg/cm ²
Turning Radius (2WS)		
Inside	12 ft 6 in.	3.8 m
Outside	19 ft 8 in.	6.02 m

Standard Specifications

Power Source

Diesel Engine		
Kubota Tier 4 Final	25 hp	18.6 kW
Motor/Generator Power	28 hp	20.9 kW
Fuel Tank Capacity	25 gal.	94.64 L
Batteries	12V 235Ah 4D AGM Maintenance-free	
System Voltage	84V-DC	
Battery Quantity	14	

Hydraulic System

• Capacity	21 gal.	79.5 L
------------	---------	--------

Tires

• Standard	15-625 Wide Lug Tread
• Optimal	18 x 19.5 Foam-filled

Standard Features

- Oscillating Axle
- 180 Degree Hydraulic Platform Rotator
- 110V-AC Receptacle in the Platform
- 5 Degree Tilt Alarm/Indicator Light
- Automatic Engine Idle, Start/Stop
- Automatic Battery Charger in Hybrid Mode
- Electric Only Capability
- Swing-Out Engine Tray
- Hourmeter
- Horn
- Control ADE® System
- Proportional Controls
- Gull-Wing Engine Hood
- Platform Console Machine Status Light Panel*
- Lifting/Tie Down Lugs
- All Motion Alarm
- Glow Plugs (Diesel Engines)
- Platform/Ground Display Battery SOC Indicator
- 220V-AC 15A Charging Cable

* Provides indicator lights at platform control console for system distress, 5 degree tilt light, and foot switch status.



Accessories & Options

- Fall Arrest Platform, Rear Entry¹:
36 x 96 in. (0.91 x 2.44 m)
- Self-Closing Gate
- Mesh to Top Rail — Bolt-on Aluminum
- Soft Touch System
- Operator Tool Tray
- 1/2 in. Airline to Platform
- Exhaust Purifier Muffler (Diesel)
- Cold Weather Start Kit²
- Hostile Environment Kit³
- Light Package⁴
- Platform Worklights
- Flashing Amber Beacon
- 110V-AC 15A Dual Cable Charging Kit
- Accessory Packages:
 - SkyPower®
 - SkyWelder®
 - SkyGlazier®
 - Pipe Rack

1. Foam-filled tires required.
2. Includes glow plugs (Diesel), battery heater, oil tank heater.
3. Includes console cover, boom wipers and cylinder bellows.
4. Includes head and tail lights, and platform worklights.

Note: Some options may increase lead time, and some option combinations may not be available.

H800AJ HYBRID

ARTICULATING BOOM LIFT



Dimensions

All dimensions are approximate.

H800AJ

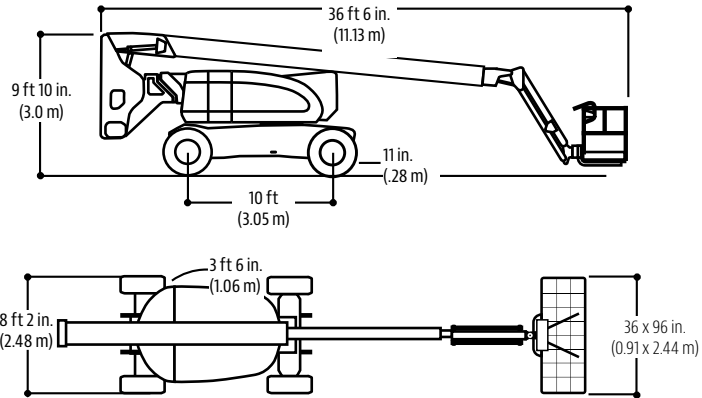

Reach Diagram

H800AJ

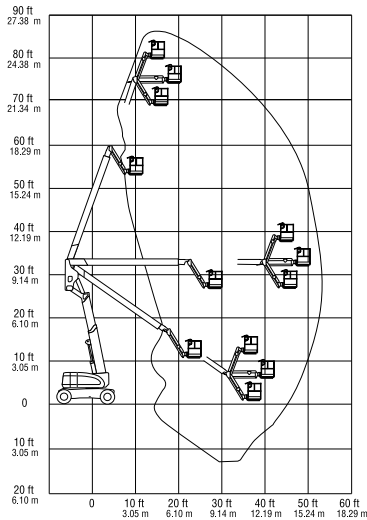

The JLG "1 & 5" Warranty

We provide coverage for one (1) full year and cover all specified major structural components for five (5) years. Due to continuous product improvements, we reserve the right to make specification and/or equipment changes without prior notification. This machine meets or exceeds applicable ANSI and CSA requirements based on machine configuration as originally manufactured for intended applications. Please reference the serial number plate on the machine for additional information.

Part No.: 3131123
R031802
Printed in USA

JLG Industries, Inc.
1 JLG Drive
McConnellsburg, PA 17233-9533
Telephone 717-485-5161
Toll-free in US 877-JLG-LIFT
Fax 717-485-6417
www.jlg.com

An Oshkosh Corporation Company