

Model EC520AJ

ELECTRIC ARTICULATING BOOM LIFT



MORE ECONOMIC

- Electric motor and battery technology for zero emissions and low noise.

MORE PRODUCTIVE

- The electric motors bring you both powerful performance with the benefit of electric efficiency
- Save time thanks to very fast charging (~3hrs)
- Lower total cost of ownership
- Zero emissions allowing you to work in low emission zones- indoor and outdoor.

MORE ACCESS

- Conquer rough terrain with standard oscillating axle delivering optimized grip and stability.

SMART DESIGN

- Reduce maintenance with Dura Tough gull-wing turntable hood and chassis embedded lithium batteries for optimal component protection.

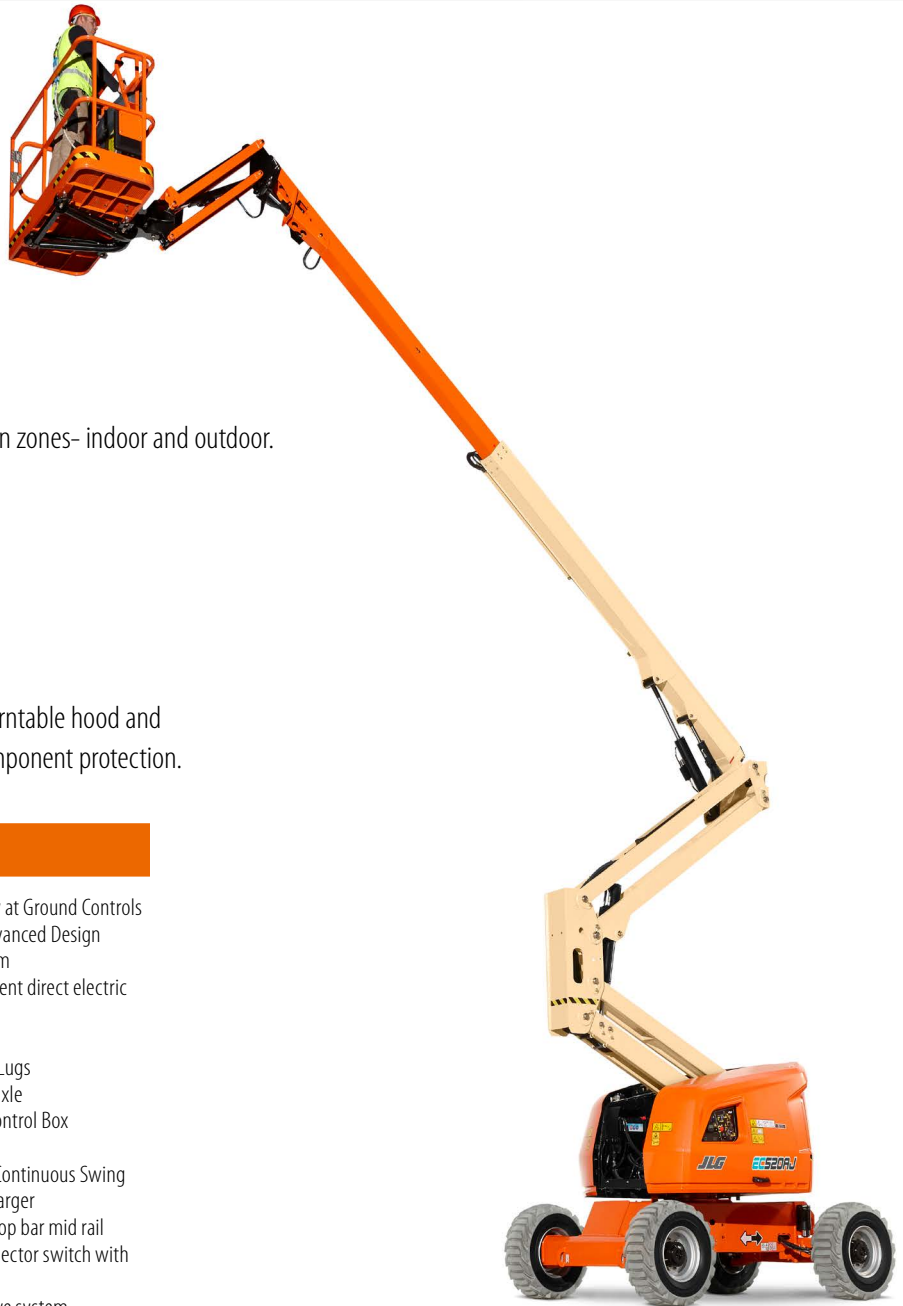

Standard Features

- Multiple function operation
- Full proportional drive joystick control with integral thumb steer switch
- Full proportional main boom and swing joystick control
- Multiple speed control for lower boom, telescope and platform rotate
- Selectable creep speed on drive / lift and swing functions
- 1.24 m articulating jib
- 180 degree powered platform rotator
- Platform console machine status light panel *
- Load sensing system
- AC power cable to platform
- 5 Degree Tilt Alarm/Indicator Light
- Dura Tough gull-wing turntable hood
- 12V DC auxiliary power
- Hourmeter
- Interactive Display at Ground Controls
- Control ADE® (Advanced Design Electronics) System
- 2 wheel independent direct electric AC drive
- Horn
- Lifting/Tie Down Lugs
- Oscillating Front Axle
- Cast Aluminum Control Box
- All motion alarm
- 355 Degree Non-Continuous Swing
- 3kW Zivan fast charger
- Side entry with drop bar mid rail
- Ground control selector switch with key lock
- JLG Skyguard active system
- Synthetic Biodegradable Hydraulic Oil
- 48V DC pump motor
- Non Mark FF 315/55 D20 Tyres

Standard Specifications

- Electrical System 12V-DC
- Batteries 144 Ah
- Drive Motors 48 V Lithium battery incl battery management system
- Hydraulic System 30 L
- Tyres Non Mark FF 315/55 D20 Tyres

Accessories & Options

- 0.76 m x 1.22 m Slide bar side entry platform
- 0.76 m x 1.22 m Self closing inward swing gate
- 0.76 m x 1.52 m Slide bar side entry platform
- 0.76 m x 1.52 m Self closing inward swing gate
- 13 mm air line to platform
- Platform Tool Tray
- Platform charger 12V
- Platform charger USB
- Arctic Hydraulic Oil
- Flashing Amber Beacon
- Hostile Environment Kit **
- Light Package
- Platform Worklights
- PipeRack
- Skyguard beacon (ILOS)
- All motion alarm (white noise)
- Head & Tail Lights
- Euro Plug & Socket
- Special paint colour
- Foam filled 315/55 D20 Tyres
- 33 x 12-20 Low profile, Solid Non Marking Tyres
- Container transport wheels 33/1550 x 16.5
- ClearSky CAN
- Cold weather paccage
- Hot weather paccage
- Bigger ground display (4")

* Provides indicator lights at platform control console for system distress, battery state of charge, 5 degree tilt light, and foot switch status.

** Includes boom wipers, cylinder bellows and console cover.

Model EC520AJ

ELECTRIC ARTICULATING BOOM LIFT

Performance

• Working height	18.0 m
• Platform height	16.0 m
• Horizontal Outreach	10.00 m
• Working Outreach **	10.65 m
• Up and Over Height	7.30 m
• Swing (Non-Continuous)	355°
• Platform Capacity - Unrestricted	250 kg
• Platform Rotator (Hydraulic)	180°
• Jib - Overall Length	1.24 m
• Jib - Range of articulation	145° (+76°/-69°)
Dimensions:	
A. Platform Size	0.76 m x 1.83 m
B. Overall Width	2.26 m
C. Tailswing (working condition)	Zero
D. Stowed Height	2.27 m
E. Stowed Length	7.77 m
F. Wheelbase	2.36 m
G. Ground Clearance	0.42 m
• Machine weight *	7,985 kg
• Maximum Ground Bearing Pressure ***	6.6 kg/cm ²
• Occupied floor area	7.5 m ²
• Drive Speed	5 km/h
• Gradeability	30%
• Turning Radius – Inside	2.06 m
• Turning Radius – Outside	4.78 m

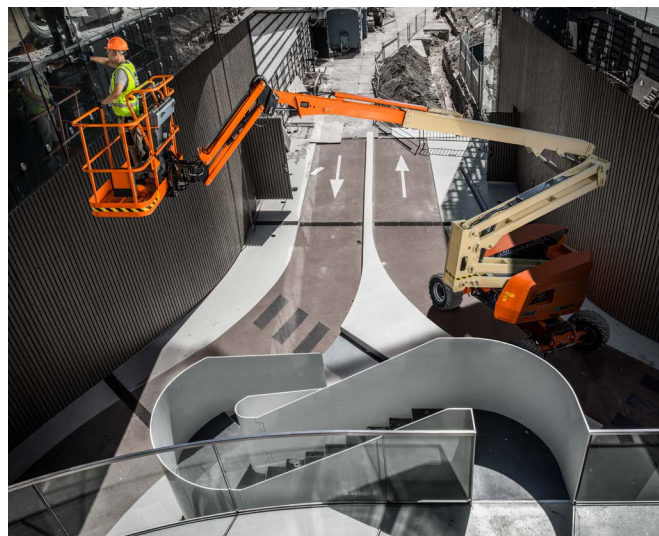

* Certain options or country standards may increase weight and/or dimensions.
 ** Incl. 0.65 m outreach beyond platform
 *** With Standard tires

Reach Diagram

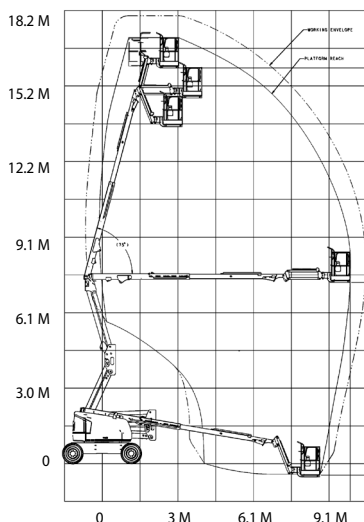

Dimensions

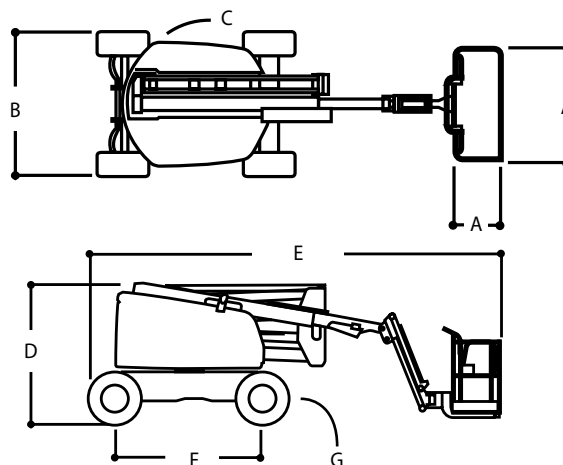

IMPORTANT

JLG is continually researching and developing products and reserves the right to make modifications without prior notice. All data in this document is indicative. Certain options or country standards will increase weight. Specifications may change to meet country standards or with the addition of optional equipment.

Due to continuous product improvements, JLG Industries reserves the right to make specification and/or equipment changes without prior notification.



JLG EMEA BV

Polaris Avenue 63
 2132 JH Hoofddorp
 The Netherlands
 Tel.: +31 (0)23 565 5665
www.jlg.com

An Oshkosh Corporation Company